



CompAir

by Gardner Denver

100% Oil-Free - Guaranteed

Oil-Free Rotary Screw Compressors
Fixed & Regulated Speed (RS)

PureAir

ISO CLASS: ZERO PLUS SILICONE FREE



D75 – D315
D110RS – D315RS

Innovative oil-free
compressed air technologies

Air and Water Cooled

Air purity that meets the most stringent hygienic standards

Outstanding reliability for demanding applications

The new two-stage oil-free screw compressor range has been designed with a focus on operational safety in demanding applications. The innovative clear construction delivers state-of-the-art performance, in-depth control and outstanding reliability. The sophisticated Delcos XL controller protects your investment by continuously monitoring operational parameters. CompAir's own designed and manufactured airend works at constant low temperature levels and lowers the compressor's lifecycle costs. With easy servicing and full Assure warranty cover, operators eliminate all possible risks to their business.



Oil-free & Silicone-free – the ultimate air quality!

No matter what industrial sector, there is a growing demand for higher quality, oil-free compressed air that meets the stringent quality standards. Whether it is needed for food and beverage or chemicals production, supply of pharmaceuticals, electronics or sensitive components, manufacturers will no longer accept the risk of product or equipment contamination. For this reason, CompAir's D-Series offers the highest standard of air purity and has been certified ISO 8573-1 Class Zero (2010) and silicone free.

▶ Pressure range

4 to 10 bar

▶ Volume flow

8.89 to 51.8 m³/min

▶ Motor power

75 to 315 kW



*Optional IE 4

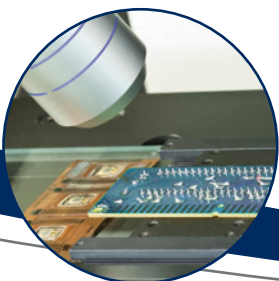

“

CompAir's commitment to providing the purest, highest quality compressed air, through the development of innovative products, delivers world-class solutions.

”



GERMAN 
ENGINEERING
& DESIGN

Engineering excellence

Compressors are more than just a financial investment, they are a key component to ensuring that manufacturers, processors and operators receive consistent, high quality, low cost air. The screw compression element is the heart of the compressor and therefore CompAir keeps the design and manufacture in-house, using the latest CNC rotor grinding machinery, coupled with online laser technology. The resulting reliability and performance ensure that operating costs will remain low throughout the compressor's life.

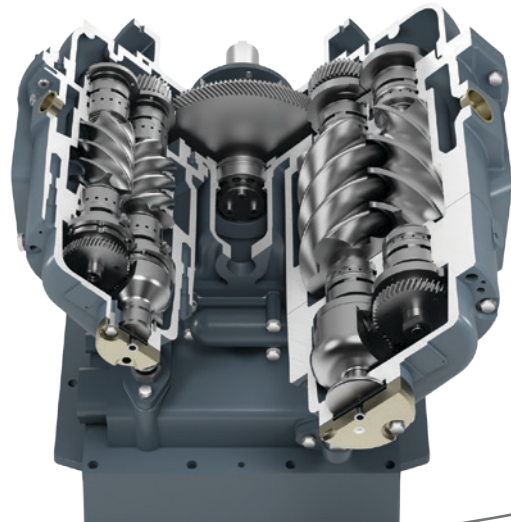

Innovative oil-free design concept

Choose the D-Series and eliminate your risks

You may have no choice over the quality of the compressed air used in your process – it just has to be absolutely contaminant free.

CompAir have been designing, manufacturing and supplying oil-free compressors for more than 90 years. The award winning D-Series has been continuously developed and achieves cutting edge performance and efficiency.

- ✓ Premium efficiency two stage airend design
- ✓ High quality IE 3 electric motor, optional IE 4
- ✓ Efficient motor cooling
- ✓ High ambient temperatures of up to 45°C
- ✓ Delcos XL touch screen controller with enhanced monitoring
- ✓ Unique closed cooling water circuit for airend cooling

PureAir
ISO CLASS: ZERO PLUS SILICONE FREE



The award-winning D-Series

Frost & Sullivan honour CompAir's advanced D-Series 2-stage oil-free screw compressors.



"The product stands out for providing high quality compressed air with reduced risk of contamination, and for its smaller footprint."

Frost & Sullivan Research Analyst

“

State-of-the-art performance
- through high efficiency
components, low pressure
losses, low temperatures and
economical control.

”



High output two stage airoend design

- 100% oil-free, near isothermal compression
- High reliability thanks to constant low temperatures

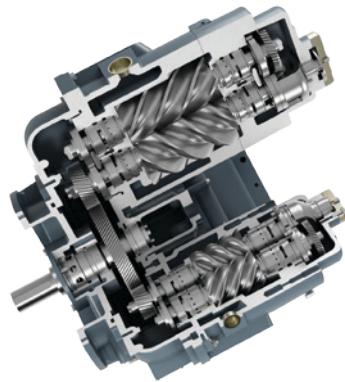

Guaranteed efficiency with IE3 electric motor

- IE4 electric motor optionally available
- Legal conformity
- High reliability
- Operational safety
- Automatic motor lubrication



Easy installation & easy servicing

- Small footprint and compact size
- All connections on one side
- Easy ducting
- Perfect service accessibility
- Low number of parts and consequently less to service
- Long-term service interval
- Separate compressed air inlet, allowing external air suction

Excellent cooling performance

- Optimum motor cooling
- Closed cooling water circuit for airoend cooling
 - For constant low temperature levels
 - Avoids pollution
 - Less gearboxes required
- Level regulated electronic condensate drain

Air cooling

- Two efficient radial fans
 - In accordance with ErP Efficiency Legislation 2015
 - Low noise level
 - Low pressure loss

Water cooling

- High quality shell and tube coolers
 - Independent from ambient temperature
 - Low noise level
- Optionally stainless steel coolers



Allows up to 45°C
ambient temperatures!

Perfect control – Perfect performance

Delcos XL innovative touch screen compressor controller

The Delcos XL with its high resolution touch screen display is extremely user-friendly and self-explanatory. All functions are clearly structured in five main menus and are intuitively visual.

The multilingual Delcos XL control system ensures reliable operation and protects your investment by continuously monitoring the operational parameters, which is essential for reducing your running costs.

Features & functions

- Precise monitoring for exceptional operational reliability
 - Ambient pressure and temperature
 - Inlet and outlet pressure and temperature at both stages
 - Network pressure and temperature
 - Oil / water pressure and temperature
 - Oil / water level
 - ...and many more
- High resolution, easy-to-use touch-screen panel
- User-friendly clear menu structure
- Integrated SD card for in-depth analysis of monitored machine parameters
- Optional with base load sequencing for up to four units

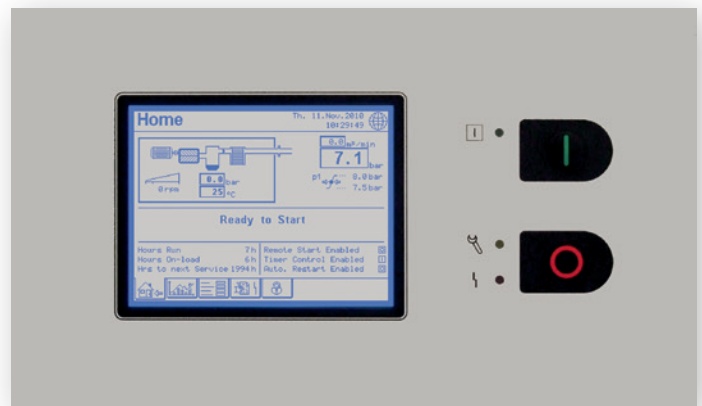

Trend diagrams

With the ability to display detailed system analysis in the form of trend diagrams and graphs, operating parameters can be precisely set to maximise efficiency.

- Network pressure
- Motor speed (regulated speed models)
- On load hours / total running hours and average volume flow
- Weekly average volume flow

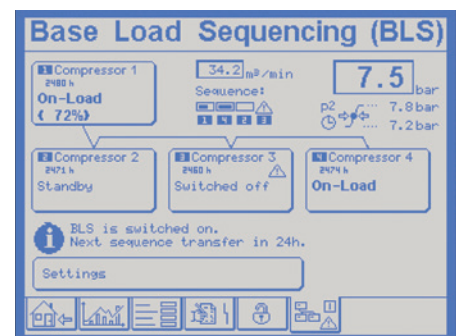
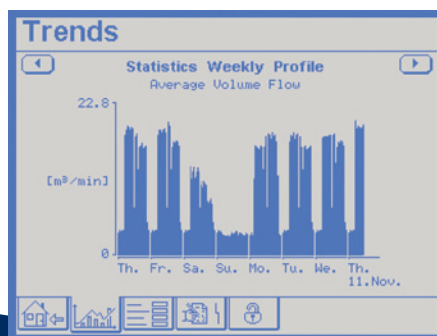
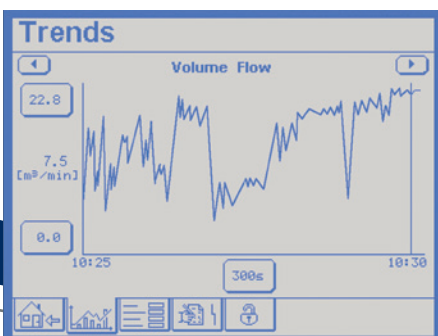



Regulated Speed Compressors

Regulated speed compressors from CompAir can efficiently and reliably handle the varying air demand found in most plant air systems.

The annual cost of ownership can be significantly reduced using regulated speed technology.

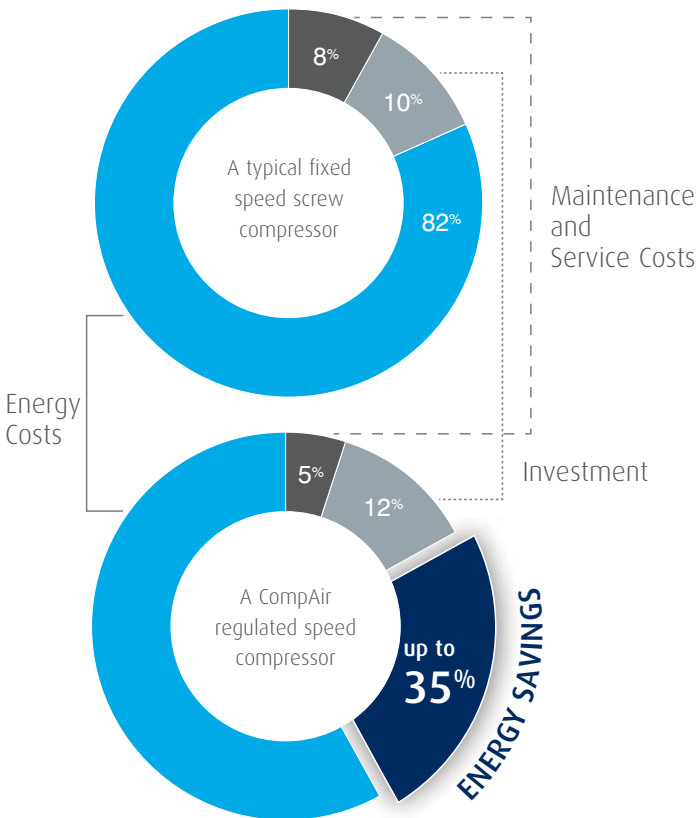

Tried and tested inverter concept

- Integrated in the electric cabinet
- Protected from dust by replaceable inlet filters
- Maximum reliability from optimised cooling system
- Ensures high availability and long-life

CompAir RS features are your benefits

The D-RS Series products are designed to obtain the greatest efficiency across the entire operating range.

- ▶ **Wide regulation range**
No cycles means substantial energy savings
- ▶ **Perfect motor - drive - airend design**
High efficiency across broad flow range

AirPlus

SmartAir Master compressed air management system

Energy management is crucial for all compressed air users, as the highest cost factor of a compressor is the energy to run it. Over a period of five years, energy accounts for typically 80% of the total costs. Compressed air systems typically comprise of multiple compressors delivering air to a common distribution system. The combined capacity of those machines is generally greater than the maximum site demand.

With CompAir's advanced demand responsive sequencer SmartAir Master, the efficiency of the compressor stations with up to twelve compressors including downstream equipment can be maximised. Apart from the energy savings, the compressed air management system also contributes to decreased downtime, optimum performance and monitoring, and ultimately leads to increased plant productivity.

Characteristics of each compressor

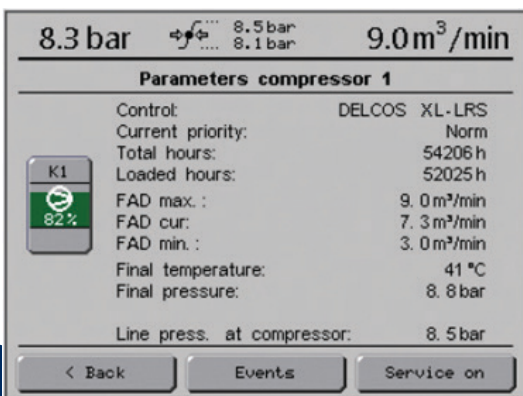

A profitable investment

- Harmonises the workload of up to 12 fixed or regulated speed compressors
- Eliminates energy waste by tightening the network pressure to the narrowest pressure band
- Equalises the running hours for economic servicing and increased uptime

Diagram display

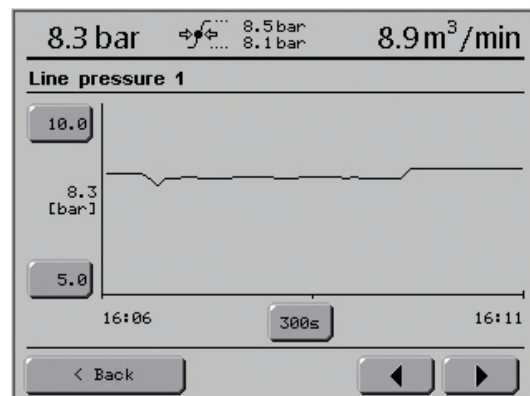

How to add further value

Heat recovery

The heat generated during compression is paid for as part of the process, then paid for again during removal by way of cooling fans. Instead of simply removing the heat, it can be used to generate free hot process water or hot water heating systems by utilising a high efficiency, factory fitted oil to water heat exchanger.

Upgrade your compressed air system with heat recovery

- Significant cost savings
- Lower CO₂ emissions
- Low investment costs
- Approximately 80% recovery

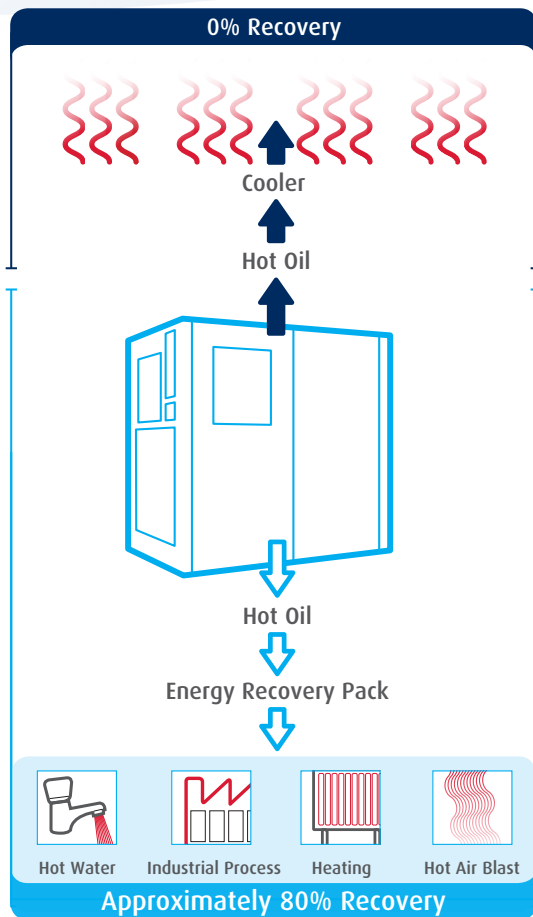

Visit www.compair.com to watch the heat recovery video and access the energy savings calculation tool.

Base load sequencing

Compressed air systems typically comprise of multiple compressors delivering air to a common distribution system. The addition of the optional base load sequencing module will allow central control of up to four compressors matching delivery to the plant demand.

Compressed air purification

A modern production system and process demands increasing levels of air quality. A CompAir compressed air system utilising the latest technology provides an energy efficient solution at lowest life cycle costs.



Water Cyclone Separator X Series

Designed for efficient removal of bulk liquid contamination from compressed air.

Compressed Air Filter CF Series

Efficient design for water, dust and particle removal.



Bekomat Condensate Drain and Oil-Water-Separation Systems

To drain compressed air condensate without loss of compressed air and separate any filtered oil to meet all the requirements of the Water Ecology Act and of other relevant provisions.



Compressed Air Refrigerant Dryer

CompAir offer a full range of energy efficient and environmentally friendly stand alone refrigerant dryers.

Heatless Desiccant Dryers

Series A_XS and A_TX.

Heat Regenerative Desiccant Dryers

Series A_TV and A_RS.



Nitrogen Generator

On-site industrial nitrogen gas generation using the factory compressed air. Designed to achieve maximum efficiency and gas quality.

Protect your investment

PureCARE

PUREAIR SERVICING & MAINTENANCE PROGRAMME



PureCARE

Specifically developed to support our oil-free product range, the CompAir PureCARE service programmes go beyond traditional service schemes to ensure uninterrupted quality compressed air supply coupled with optimum compressor performance, giving you peace of mind for your production and budgeting processes.

PureCARE Service plans are delivered by factory-trained CompAir technicians specifically to keep your oil-free compressed air system at peak performance, supported by the unrivalled quality and performance of CompAir genuine parts. Each PureCare Service plan is tailored to your specific application and site circumstances, ensuring system reliability and productivity at optimum cost.

Compact design – easy installation

The small footprint reduces the space required for installation.

Easy servicing

The design of these packages ensures that the service points are readily accessible. The enclosure side doors are hinged and removable to allow complete access to all service points. The reduced number of moving parts further lowers the maintenance costs.

CompAir genuine spare parts

Enjoy complete peace of mind.

Genuine CompAir parts and lubricants ensure that compressed air plant reliability and efficiency is maintained at the highest standards. CompAir spare parts and lubricants are distinguished by:

- Long service life, even under harshest conditions
- Minimum losses contributing to energy savings
- High reliability improving plant up-time
- Products manufactured with the strictest Quality Assurance Systems



CompAir D-Series - Technical Data

D75 – D315 Fixed Speed

Compressor Model	Cooling Method	Motor Rating [kW]	Working Pressure [bar g]	Free Air Delivered ¹⁾ [m ³ /min]		Dimensions L x W x H [mm]	Noise Level ²⁾ [dB(A)]		Weight [kg]
				8 bar g	10 bar g		8 bar g	10 bar g	
D75	Air	75	8 - 10	12.91	10.63	2597 x 1744 x 2001	75	74	3023
	Water						72	70	
D90	Air	90	8 - 10	15.65	13.79	2597 x 1744 x 2001	76	75	3223
	Water						73	72	
D110	Air	110	8 - 10	19.51	17.39	2597 x 1744 x 2001	77	77	3265
	Water						75	74	
D132	Air	132	8 - 10	22.39	20.50	2597 x 1744 x 2001	78	78	3432
	Water						77	76	
D160	Air	160	10	-	22.33	2597 x 1744 x 2001	-	78	3644
	Water							77	
D165	Water	160	8 - 10	29.1	24.9	3300 x 1994 x 2190	77	78	4715
D200	Water	200	8 - 10	36.1	32	3300 x 1994 x 2190	80	81	5060
D250	Water	250	8 - 10	44.5	37.2	3300 x 1994 x 2190	81	82	5215
D315	Water	315	8 - 10	49.2	44.5	3300 x 1994 x 2190	81	82	5520

D110RS – D315RS Regulated Speed

Compressor Model	Cooling Method	Motor Rating [kW]	Working Pressure [bar g]	Free Air Delivered ¹⁾ [m ³ /min]		Dimensions L x W x H [mm]	Noise Level at 70% Load ²⁾ [dB(A)]	Weight [kg]
				min.	max.			
D110RS-8	Air	110	4 - 8	8.89	19.51	2597 x 1744 x 2001	76	3278
	Water						72	
D110RS-10	Air	110	4 - 10	10.51	17.68	2597 x 1744 x 2001	76	3278
	Water						71	
D132RS-8	Air	132	4 - 8	8.95	22.95	2597 x 1744 x 2001	77	3476
	Water						73	
D132RS-10	Air	132	4 - 10	10.51	21.10	2597 x 1744 x 2001	77	3476
	Water						72	
D160RS-10	Air	160	4 - 10	10.40	23.52	2597 x 1744 x 2001	77	3688
	Water						73	
D200RS-8.5	Water	200	4 - 8.5	17.3	37.4	3300 x 1994 x 2190	77	5110
D200RS-10	Water	200	4 - 10	18	33.2	3300 x 1994 x 2190	79	5110
D250RS-8.5	Water	250	4 - 8.5	17.4	46.9	3300 x 1994 x 2190	78	5265
D250RS-10	Water	250	4 - 10	18.4	41.7	3300 x 1994 x 2190	79	5265
D315RS-8.5	Water	315	4 - 8.5	16.6	51.1	3300 x 1994 x 2190	78	5570
D315RS-10	Water	315	4 - 10	18.3	48.5	3300 x 1994 x 2190	79	5570

¹⁾ Data measured and stated in accordance with ISO 1217, Edition 4, Annex C and Annex E and the following conditions:
Air Intake Pressure 1 bar a, Air Intake Temperature 20°C, Humidity 0 % (Dry).

²⁾ Measured in free field conditions in accordance with ISO 2151, tolerance ± 3dB (A).



Global experience – truly local service

With over 200 years of engineering excellence, the CompAir brand offers an extensive range of highly reliable, energy efficient compressors and accessories to suit all applications.

An extensive network of dedicated CompAir sales companies and distributors across all continents provide global expertise with a truly local service, ensuring our advanced technology is backed up with the right support.

As part of the worldwide Gardner Denver operation, CompAir has consistently been at the forefront of compressed air systems development, culminating in some of the most energy efficient and low environmental impact compressors on the market today, helping customers achieve or surpass their sustainability targets.



CompAir compressed air product range

Advanced Compressor Technology Lubricated

- Rotary Screw
 - > Fixed and Regulated Speed
- Piston
- Portable

Oil-Free

- Water Injected Screw
 - > Fixed and Regulated Speed
- Two Stage Screw
 - > Fixed and Regulated Speed
- Piston
- High Speed Centrifugal - Quantima®
- Rotary Scroll

Complete Air Treatment Range

- Filter
- Refrigerant and Desiccant Dryer
- Condensate Management
- Heat of Compression Dryer
- Nitrogen Generator

Modern Control Systems

- CompAir DELCOS Controllers
- SmartAir Master Sequencer

CompAir policy is one of continuous improvement and we therefore reserve the right to alter specifications and prices without prior notice. All products are sold subject to the Company's conditions of sale.

Value Added Services

- Professional Air Audit
- Performance Reporting
- Leak Detection

Leading Customer Support

- Custom Engineered Solutions
- Local Service Centres
- Genuine CompAir Parts and Lubricants

www.compair.com · sales@compair.com